

ABCOR[®] - TUBULAR ULTRA-COR[®] 7 PLUS: 10-HFM-183-UEP

Ultrafiltration Multitubular Module for Cathodic Electrocoat Paint

PRODUCT DESCRIPTION

KMS Part Number:	0711942
Membrane Chemistry:	PVDF
Membrane Type:	HFM (positively charged)
Membrane Area:	7.2 ft ² (0.67 m ²)
Housing Construction:	PVC
Gasket:	EPDM
Interconnecting Components:	See Reverse

OPERATING AND DESIGN INFORMATION*

Maximum Inlet Pressure:	70 psi @ 120°F (4.8 bar @ 49°C)
Minimum Outlet Pressure:	5 psi (0.3 bar)
Maximum Operating Temperature:	120°F (49°C)
Maximum Permeate Side Back Pressure:	5 psi (0.3 bar)
Maximum Feed Side Pressure Drop:	6.5 psi @ 120°F (0.4 bar @ 49°C)
Allowable pH – Continuous Operation:	3 – 7 @ 130°F (54°C)
Allowable pH – Short Term Cleaning:	2 – 7 @ 130°F (54°C)

* Consult KMS Process Technology for specific applications.

FEED FLOW VS. PRESSURE DROP

Circulation Flow	Crossflow Velocity		Pressure Drop		
	gpm	m ³ /hr	fps	m/s	psi
23	5.2	6.4	2.0	2.0	0.14
34	7.7	9.5	2.9	4.3	0.29
42	9.5	11.7	3.6	6.0	0.41

* Koch Membrane Systems, Inc. must review operating and cleaning conditions for all new plants as well as changes to any existing plants. Data based on Water at 77° F and a specific gravity of 1.0. Circulation rates exhibit variances of 15%.

NOMINAL DIMENSIONS

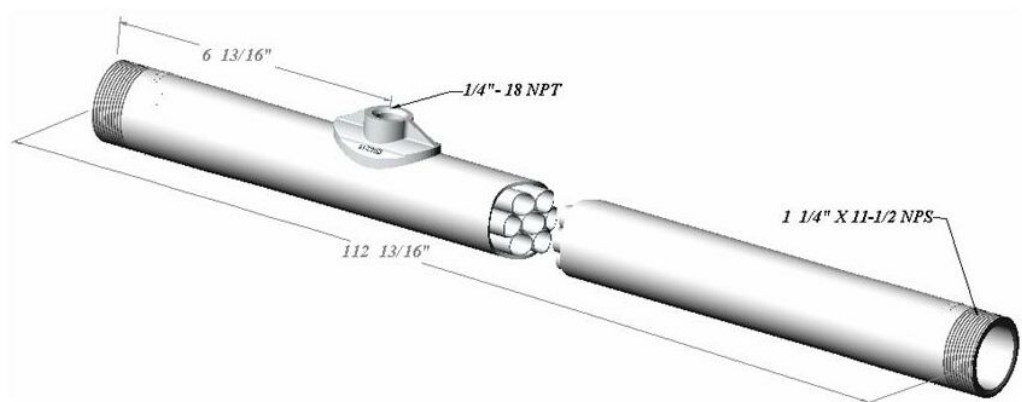

ANCILLARY PARTS

KMS recommends that these membranes be used with KMS supplied ancillary parts. Sealing is provided by o-rings and gaskets. No additional sealing compound or tape is recommended for use on threaded connections.

Item	Description	KPN
1	U-Bend Assembly (PVC)	0020390
2	Holding Nut	0020281
3	Snap Ring	0020310
4	Membrane Washer (EPDM)*	0020372
5	Permeate Pass Kit	0211798
6	Permeate Straight Connector	0211800
7	Permeate Tee Connector	0211803
8	Permeate Elbow*	0211804

* Supplied with Membrane

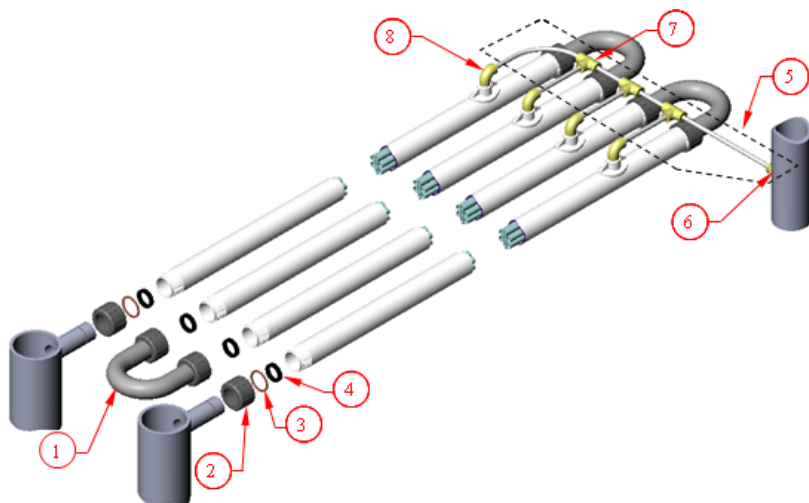

MEMBRANE INCOMPATIBILITY

Prior to exposing the membrane to any chemical, the chemical should be reviewed by Koch Membrane Systems. Aside from the listed chemicals below, synthetic coolants, semi-synthetic coolants, kerosenes, naphtha, gasoline, floc polymers may affect membrane performance.

Chemicals that should be avoided include the following:

- Aprotic Solvent (e.g., Dimethyl Formamide, Dimethyl Acetamide, N-Methyl Pyrrolidine, etc.)
 - Chlorinated Solvents (e.g., Methylene Chloride, Chloroform, Carbon Tetrachloride, etc.)
 - Ketones (e.g., Acetone, Diacetone Alcohol, etc.)
- Silicones or Silicone based Defoamers (e.g., Siloxane)

The information contained in this publication is believed to be accurate and reliable, but is not to be construed as implying any warranty or guarantee of performance. We assume no responsibility, obligation or liability for results obtained or damages incurred through the application of the information contained herein. Refer to Standard Terms and Conditions of Sale and Performance Warranty documentation for additional information.

Koch Membrane Systems, Inc., www.kochmembrane.com

Corporate Headquarters: 850 Main Street, Wilmington, Massachusetts 01887-3388, US, Tel. Toll Free: 1-888-677-5624, Telephone: 1-978-694-7000, Fax: 1-978-657-5208
European Headquarters: Koch Chemical Technology Group Ltd., Units 3-6, Frank Foley Way, Stafford ST16 2ST, GB, Telephone: +44-178-527-2500, Fax: +44-178-522-3149

• San Diego US • Aachen DE • Lyon FR • Madrid ES • Milan IT • Wijnegem BE • Beijing & Shanghai CN • Mumbai & Chennai IN • Melbourne & Sydney AU • Singapore • Sao Paulo BR • Manama BH •

The FLOW LINES DESIGN, ABCOR®, ULTRA-COR® and KOCHKLEEN are registered trademarks of Koch Membrane Systems, Inc. in the US and other countries. The STYLIZED K is a registered trademark of Koch Industries, Inc. in the US and other countries. Koch Membrane Systems, Inc. is a Koch Chemical Technology Group, LLC company.
 © 2009 Koch Membrane Systems, Inc. All rights reserved worldwide. 11/09